

MANUAL TRANSMISSION

SECTION **MT**

CONTENTS

PREPARATION	MT- 2
ON-VEHICLE SERVICE	MT- 4
REMOVAL AND INSTALLATION	MT- 5
MAJOR OVERHAUL	MT- 6
DISASSEMBLY	MT-10
INSPECTION	MT-15
ASSEMBLY	MT-17
SERVICE DATA AND SPECIFICATIONS (S.D.S.)	MT-27

MT

PREPARATION

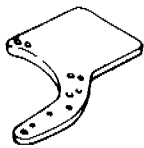
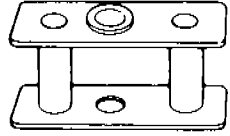
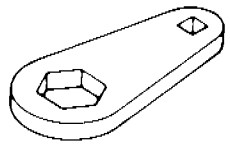
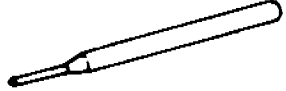
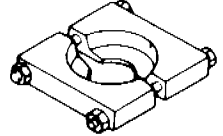
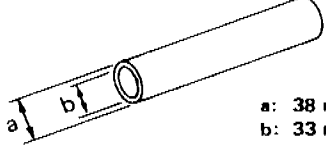
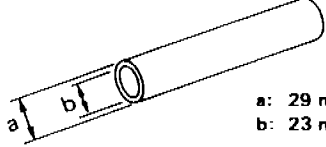
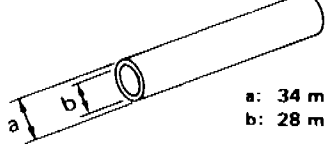
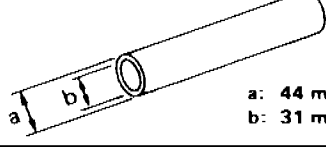

SPECIAL SERVICE TOOLS

*: Special tool or commercial equivalent

Tool number Tool name	Description
ST23810001 Adapter setting plate	 <p style="text-align: right;">Fixing adapter plate with gear assembly</p>
KV31100401 Transmission press stand	 <p style="text-align: right;">Pressing counter gear and mainshaft</p>
ST22520000 Wrench	 <p style="text-align: right;">Tightening mainshaft lock nut</p>
ST23540000* Pin punch	 <p style="text-align: right;">Removing and installing fork rod retaining pin</p>
ST30031000* Puller	 <p style="text-align: right;">Removing and installing 1st gear bushing Removing main drive gear bearing Measuring wear of baulk rings</p>
ST23860000* Drift	 <p style="text-align: right;">Installing counter drive gear</p> <p style="text-align: right;">a: 38 mm (1.50 in) dia. b: 33 mm (1.30 in) dia.</p>
ST22360002* Drift	 <p style="text-align: right;">Installing counter gear front and rear end bearings</p> <p style="text-align: right;">a: 29 mm (1.14 in) dia. b: 23 mm (0.91 in) dia.</p>
ST22350000* Drift	 <p style="text-align: right;">Installing O.D. gear bushing</p> <p style="text-align: right;">a: 34 mm (1.34 in) dia. b: 28 mm (1.10 in) dia.</p>
ST23800000* Drift	 <p style="text-align: right;">Installing front cover oil seal</p> <p style="text-align: right;">a: 44 mm (1.73 in) dia. b: 31 mm (1.22 in) dia.</p>

PREPARATION

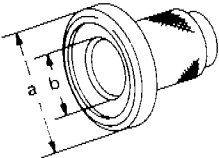
*: Special tool or commercial equivalent

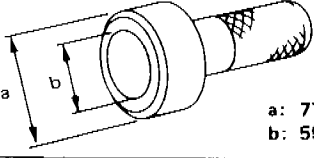
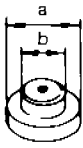
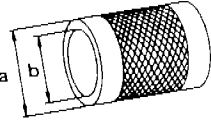
Tool number Tool name	Description
ST33400001* Drift	 <p>a: 60 mm (2.36 in) dia. b: 47 mm (1.85 in) dia.</p>
ST33290001* Puller	 <p>Removing rear oil seal</p>
ST30720000* Drift	 <p>a: 77 mm (3.03 in) dia. b: 55.5 mm (2.185 in) dia.</p>
ST30613000* Drift	 <p>a: 71.5 mm (2.815 in) dia. b: 47.5 mm (1.870 in) dia.</p>
ST33200000* Drift	 <p>a: 60 mm (2.36 in) dia. b: 44.5 mm (1.752 in) dia.</p>

COMMERCIAL SERVICE TOOL

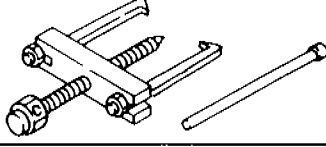
Tool name	Description
Puller	 <p>Removing counter bearings, counter drive and O.D. gears</p>

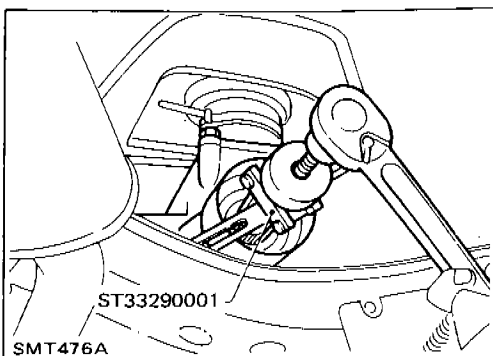

Replacing Rear Oil Seal
REMOVAL

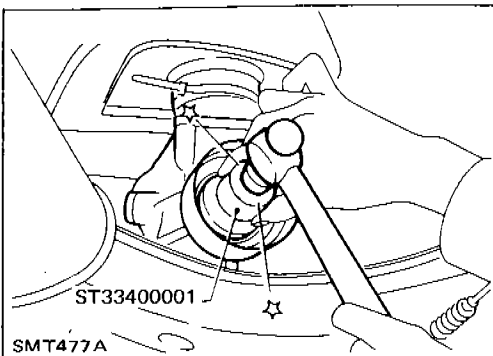

INSTALLATION

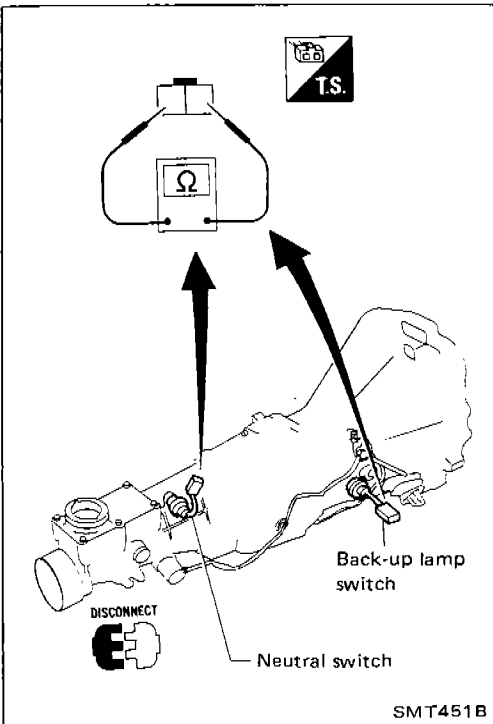

Check of Position Switch

BACK-UP LAMP SWITCH

- Check continuity.

Gear position	Continuity
Reverse	Yes
Except reverse	No

NEUTRAL SWITCH

- Check continuity.

Gear position	Continuity
Neutral	Yes
Except neutral	No

REMOVAL AND INSTALLATION

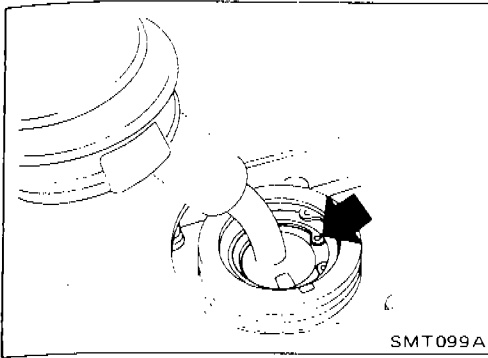

Removal

- Remove shift lever.

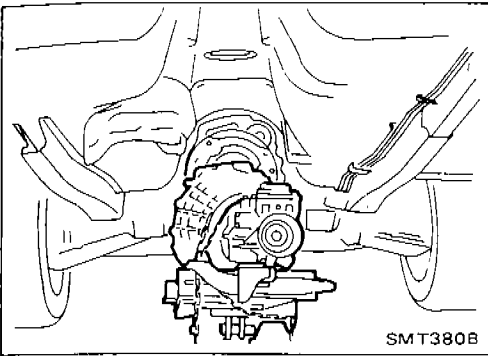

- Remove propeller shaft. — Refer to section PD.
- **Insert plug into rear oil seal after removing propeller shaft.**
- **Be careful not to damage spline, sleeve yoke and rear oil seal, when removing propeller shaft.**
- Support engine by placing a jack under oil pan.
- **Do not place jack under oil pan drain plug.**
- Remove transmission from engine.
- **Support manual transmission, while removing it.**

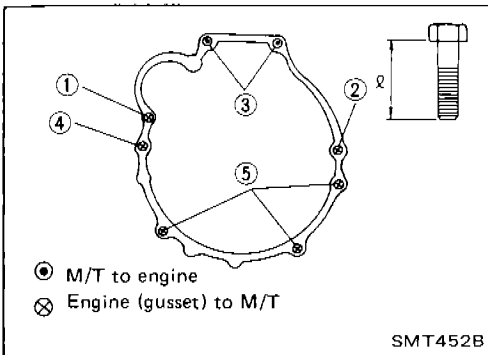

Installation

- Tighten all transmission bolts.

Bolt No.	Tightening torque N·m (kg·m, ft·lb)	ℓ mm (in)
1	39 - 49 (4.0 - 5.0, 29 - 36)	80 (3.15)
2	39 - 49 (4.0 - 5.0, 29 - 36)	75 (2.95)
3	39 - 49 (4.0 - 5.0, 29 - 36)	65 (2.56)
4	29 - 39 (3.0 - 4.0, 22 - 29)	40 (1.57)
5	29 - 39 (3.0 - 4.0, 22 - 29)	25 (0.98)
Gusset to engine	29 - 39 (3.0 - 4.0, 22 - 29)	20 (0.79)

MAJOR OVERHAUL

Case Components

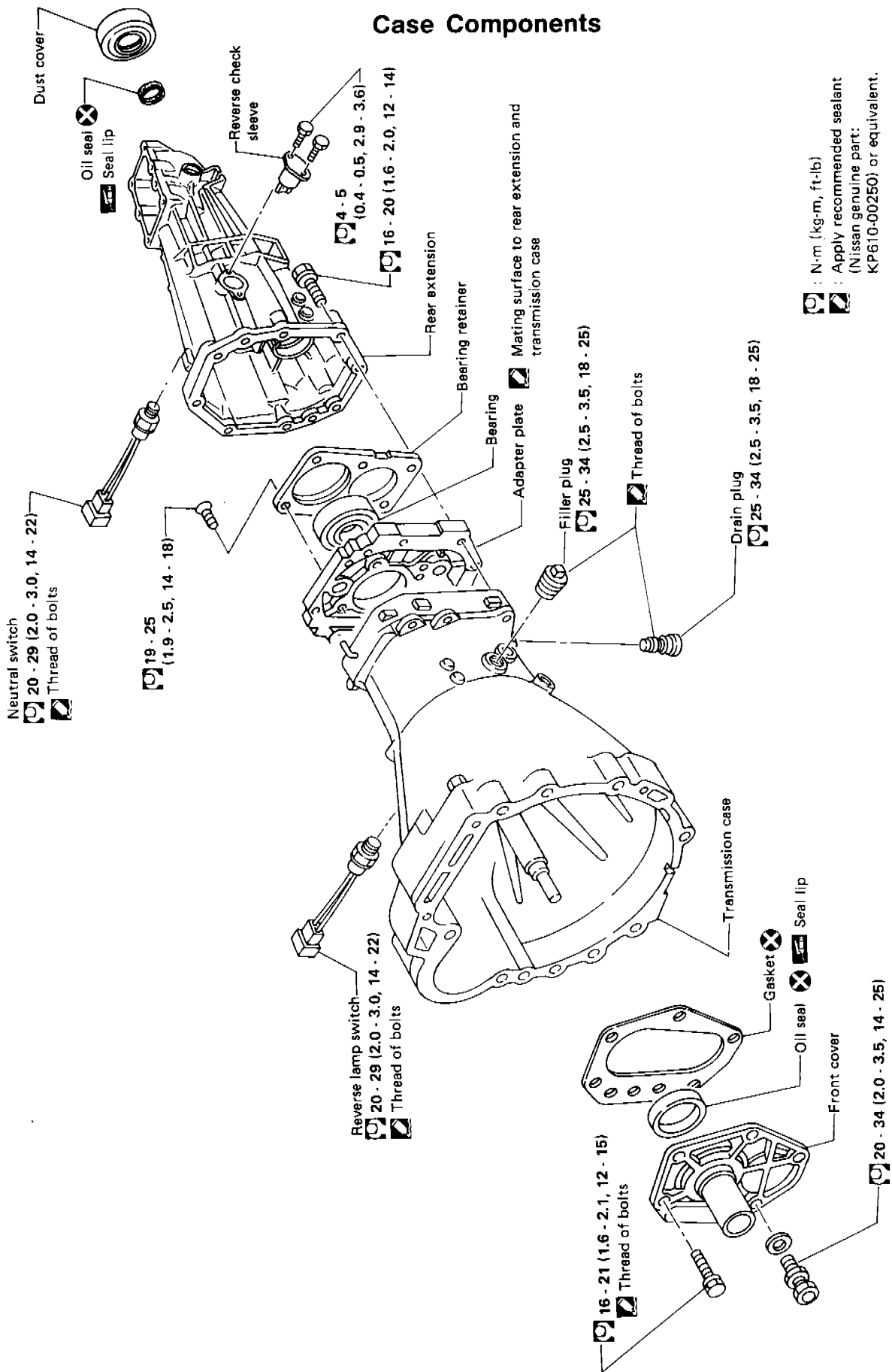

MT-6

SMT746A

MAJOR OVERHAUL

Gear Components

FOR EUROPE

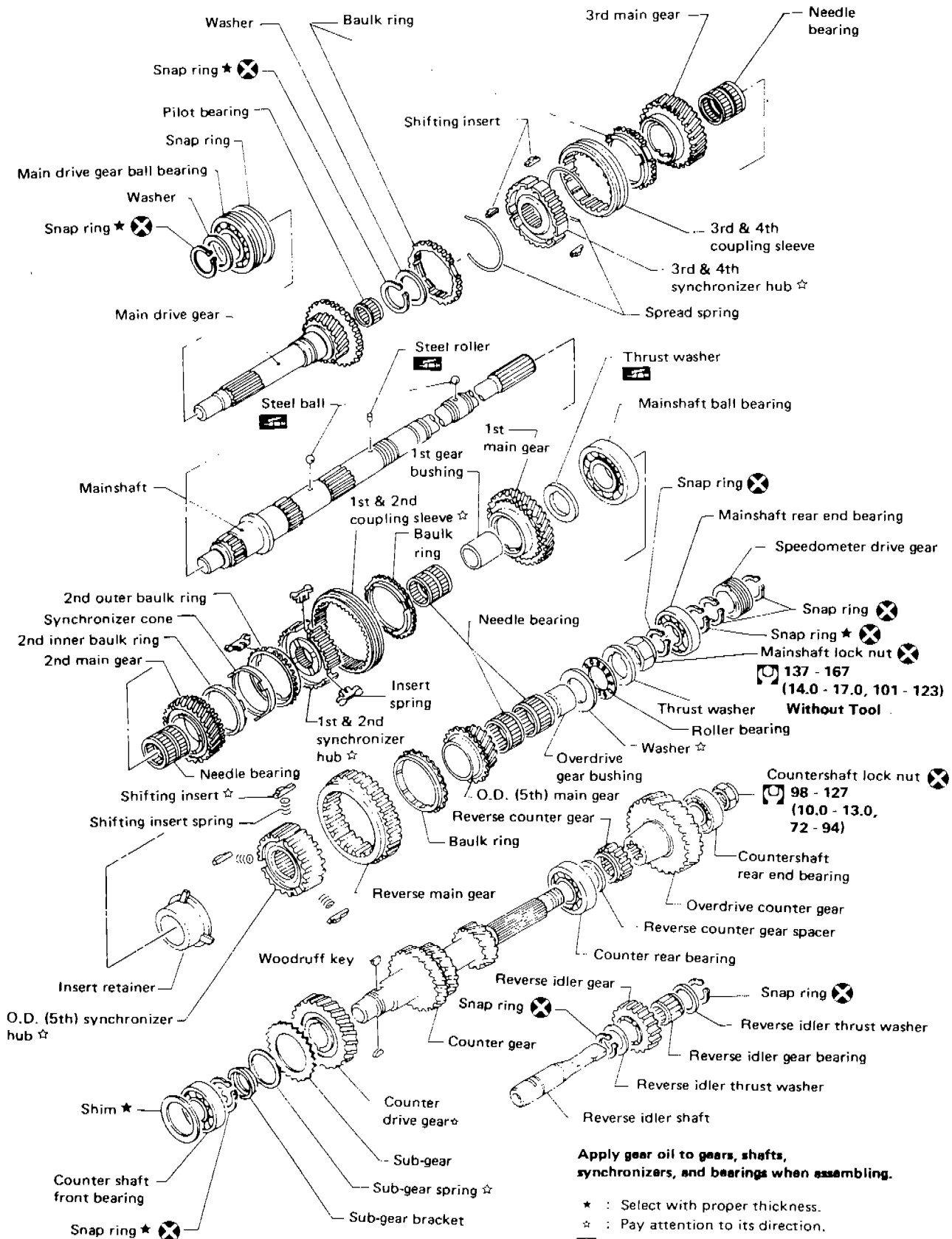

SMT037B

MT-7

MAJOR OVERHAUL

Gear Components (Cont'd)

EXCEPT FOR EUROPE

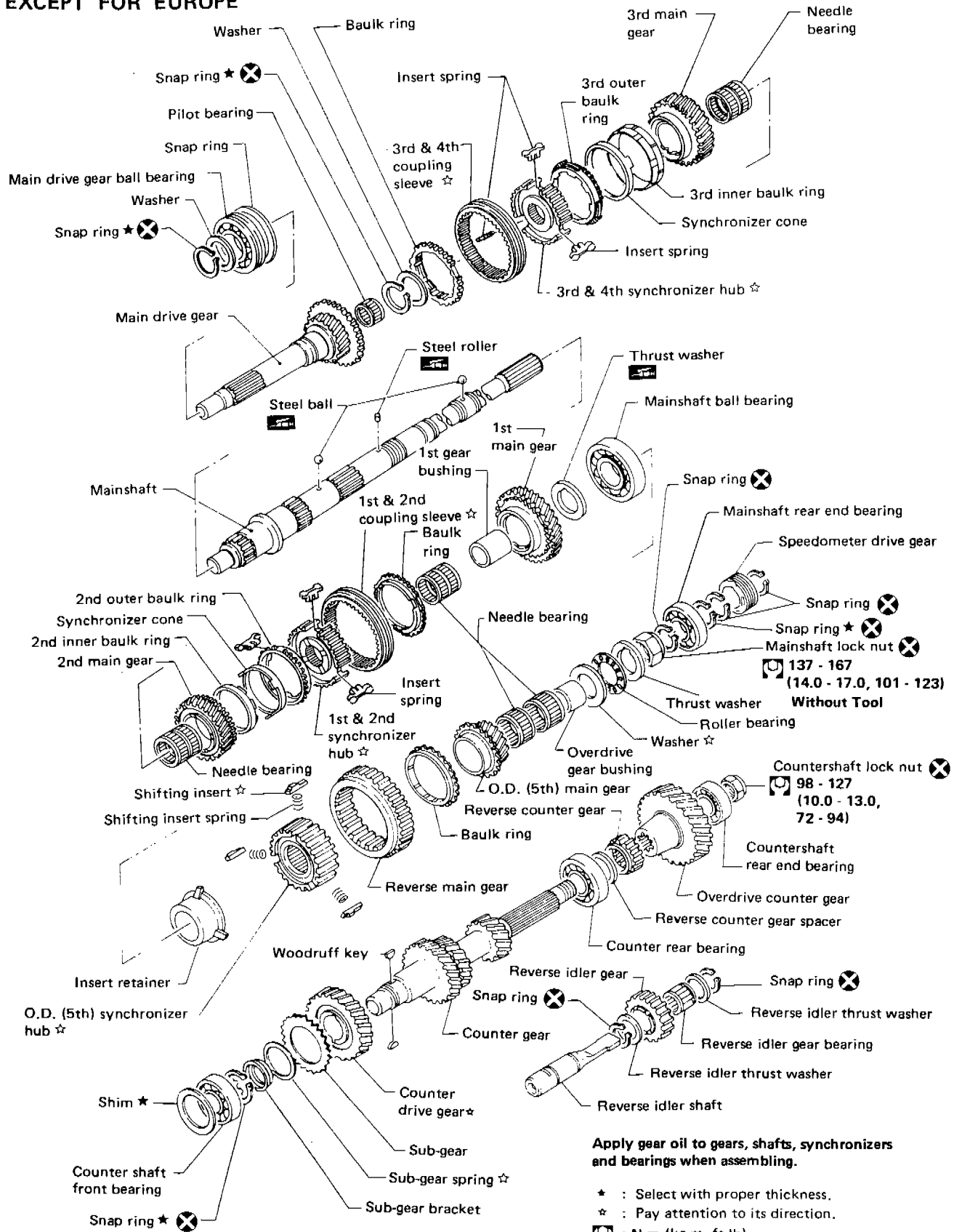

Apply gear oil to gears, shafts, synchronizers and bearings when assembling.

★ : Select with proper thickness.

☆ : Pay attention to its direction.

☐ : N·m (kg·m, ft·lb)

SMT410B

MT-8

MAJOR OVERHAUL

Shift Control Components

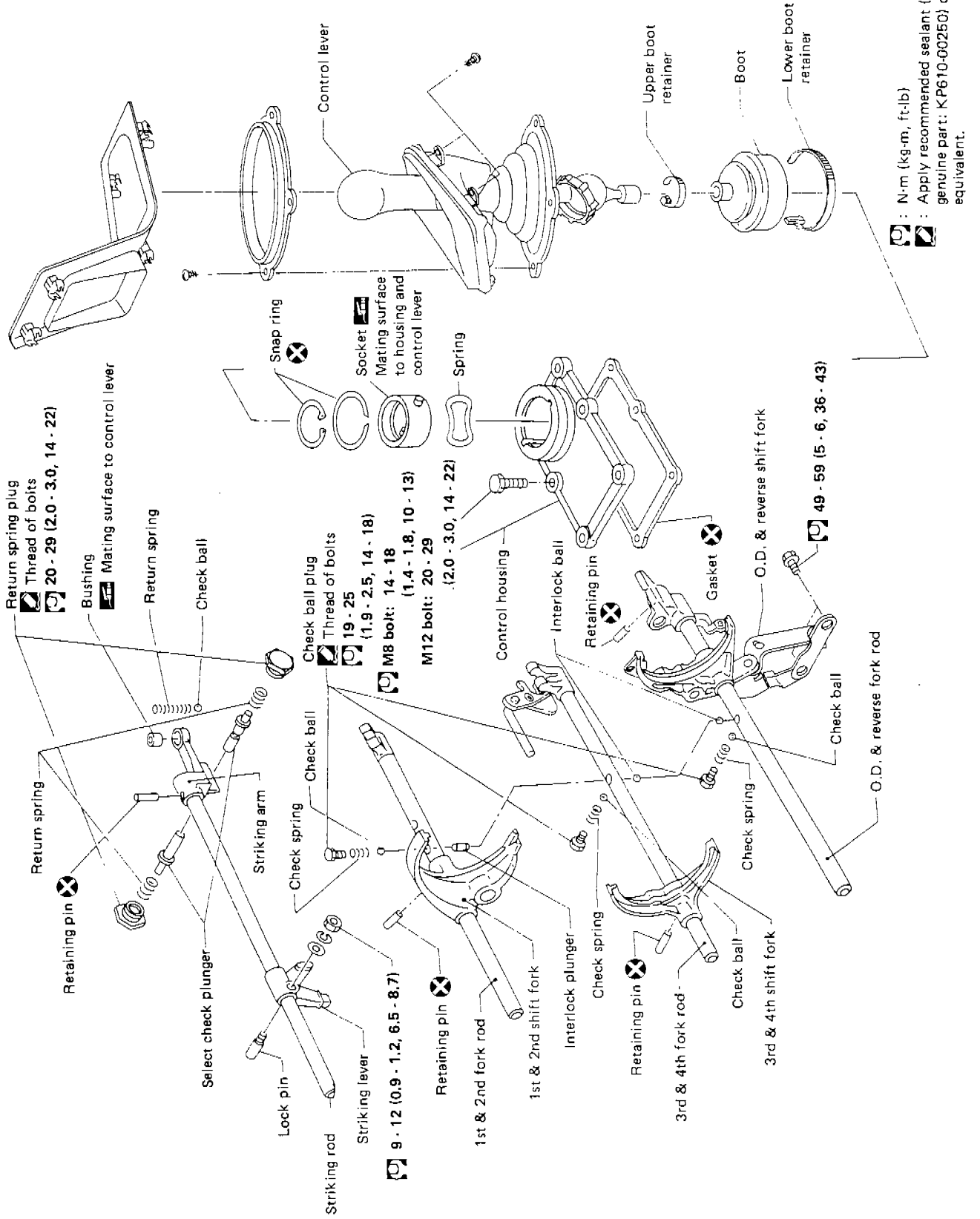

: N·m (kg·m, ft·lb)
 : Apply recommended sealant (Nissan genuine part: KP610-00250) or equivalent.

DISASSEMBLY

Case Components

1. Remove rear extension.
 - a. Remove control housing, check ball, return spring plug, select check plunger and return springs.

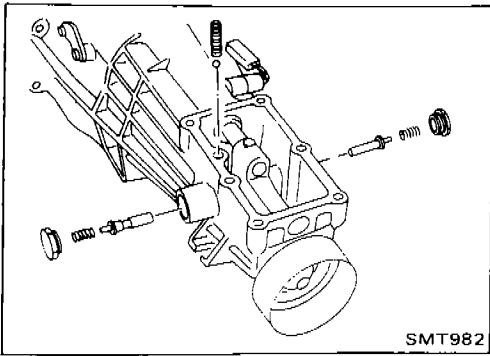

- b. Remove rear extension by lightly tapping it.

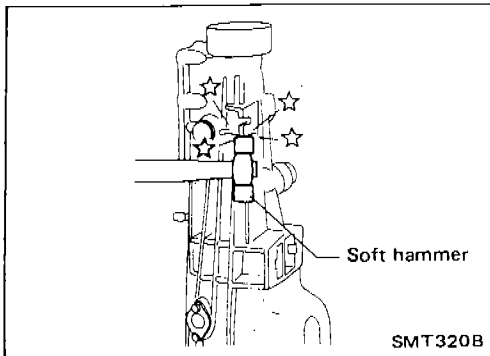

2. Remove front cover, gasket, shim of countershaft front bearing, and snap ring of main drive gear ball bearing.

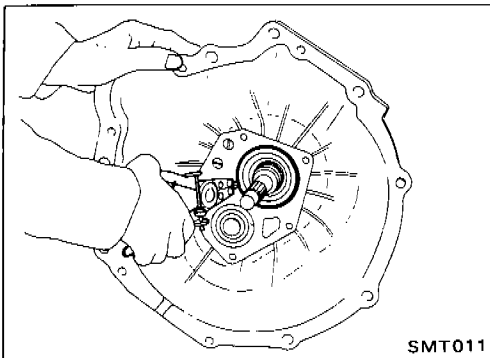

3. Remove transmission case by tapping lightly.

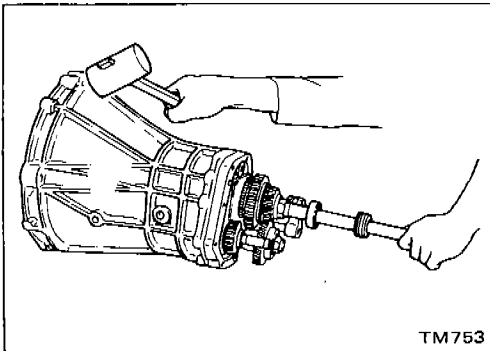

4. Remove front cover oil seal.

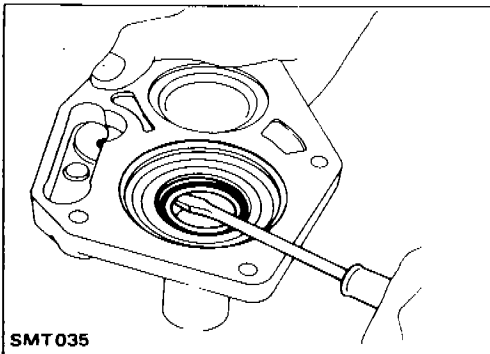

DISASSEMBLY

Shift Control Components

1. Set up Tool on adapter plate.
2. Remove check ball plugs, check springs, and check balls.

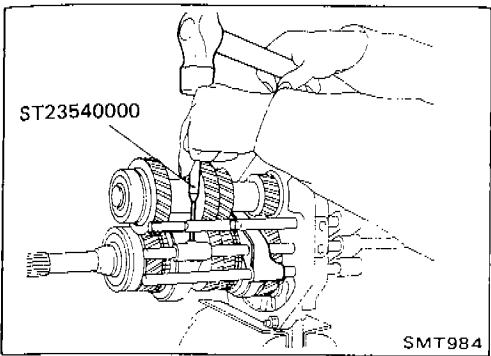
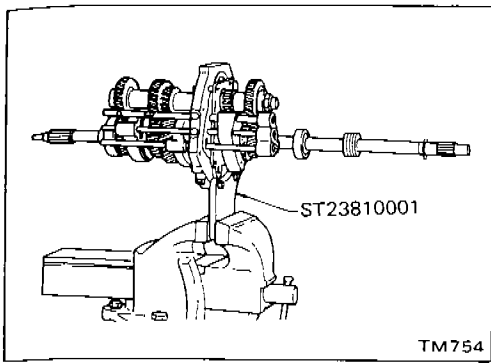

3. Drive out retaining pins. Then drive out fork rods and remove interlock balls.

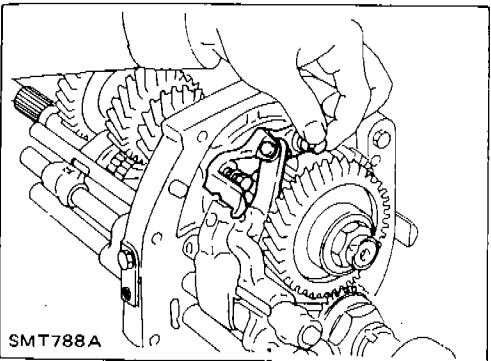

4. Remove lever bracket securing bolt.

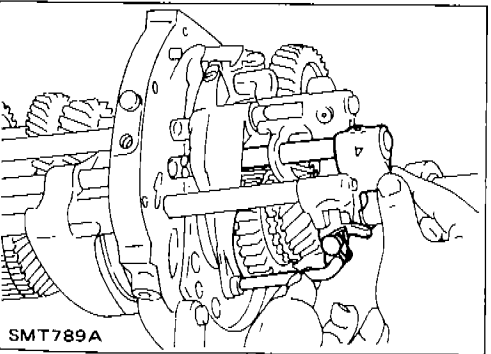

5. Draw out 3rd-4th fork rod.

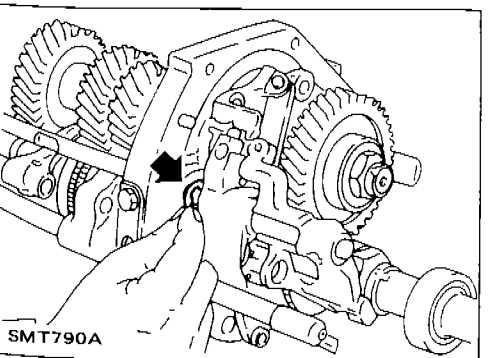

6. Remove E-ring from O.D. and reverse fork rod.

DISASSEMBLY

Shift Control Components (Cont'd)

7. Draw out O.D. and reverse fork shaft by rotating O.D. and reverse bracket counterclockwise.

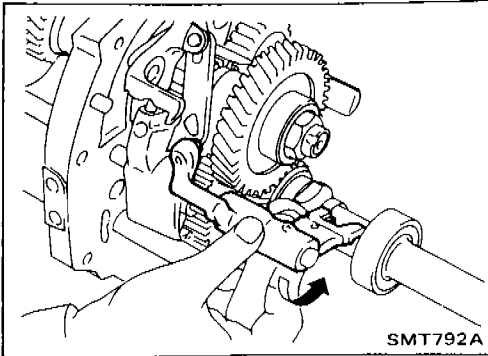

Gear Components

1. Before removing gears and shafts, measure each gear end play.

Gear end play: Refer to S.D.S.

If not within specification, disassemble and check contact surface of gear to hub, washer, bushing, needle bearing and shaft.

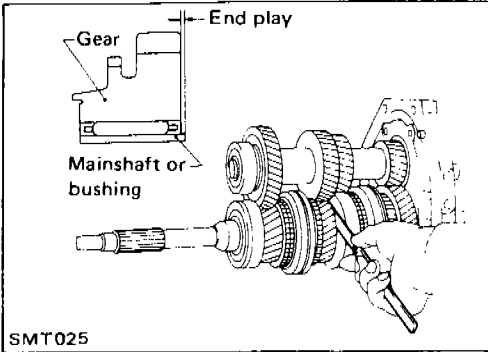

2. Mesh 2nd and reverse gear, then draw out counter front bearing with suitable puller.
3. Remove snap ring and then remove sub-gear bracket, sub-gear spring and sub-gear.

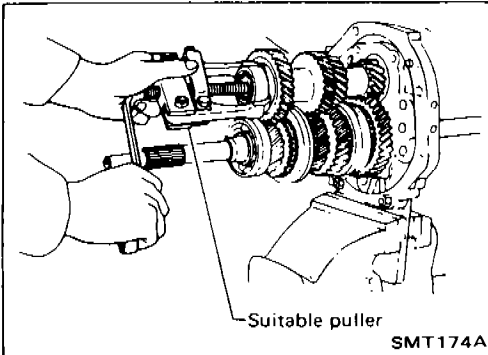

4. Draw out counter drive gear with main drive gear assembly with suitable puller.

- When drawing out main drive gear assembly, be careful not to drop pilot bearing and baulk ring.

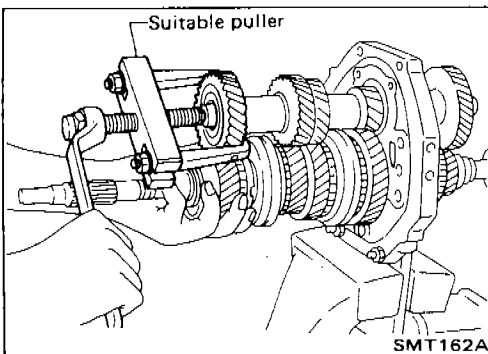

5. Remove rear side components on mainshaft and counter gear.

- a. Release staking on countershaft nut and mainshaft nut and loosen these nuts.

Mainshaft nut: Left-hand thread

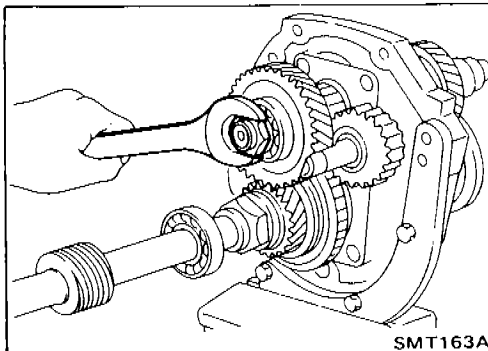

DISASSEMBLY

Gear Components (Cont'd)

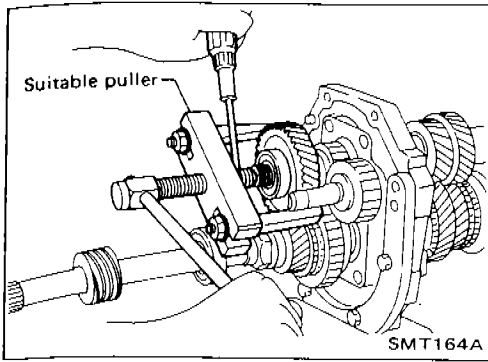

- b. Pull out O.D. counter gear with bearing with suitable puller.
- c. Draw out reverse counter gear and spacer.
- d. Remove snap rings from reverse idler shaft and draw out reverse idler gear, thrust washers and reverse idler gear bearing.
- e. Remove speedometer drive gear and steel ball.

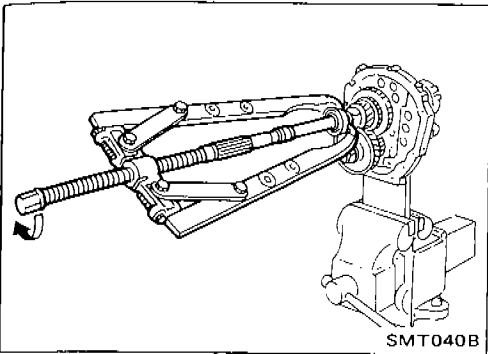

- f. Remove snap ring and pull out overdrive mainshaft bearing, then remove snap ring.
- g. Remove mainshaft nut.
- h. Remove steel roller and washer.
- i. Remove roller bearing and washer.
- j. Remove O.D. main gear, needle bearing and baulk ring (O.D.).
- k. Remove O.D. coupling sleeve, shifting inserts and shifting insert springs.

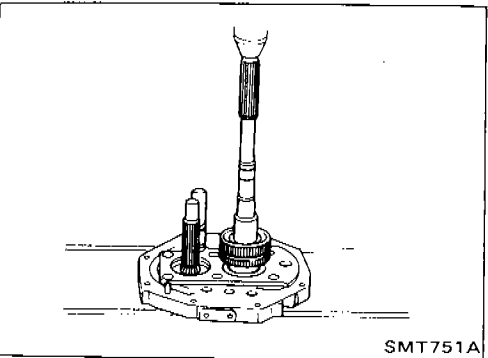

- l. Press out mainshaft and counter gear alternately.
 - **Make sure to alternate pressing of mainshaft and counter gear so as not to allow the front surface of one to contact the rear surface of the other.**

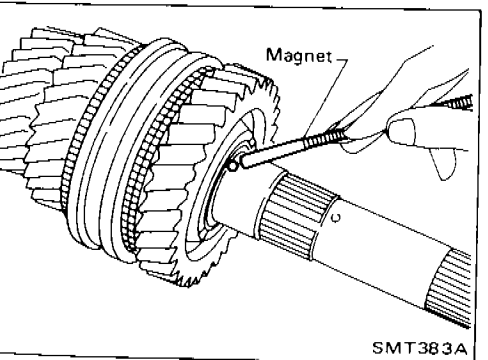

6. Remove front side components on mainshaft.
 - a. Remove 1st gear washer and steel ball.
 - b. Remove 1st main gear and 1st gear needle bearing.

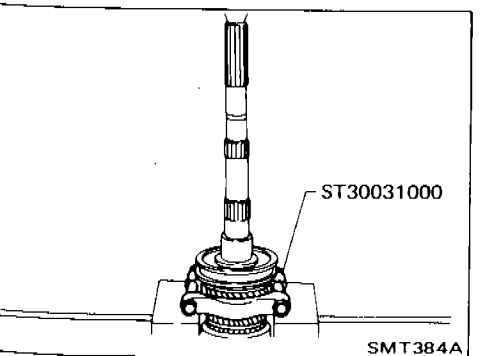

- c. Press out 2nd main gear together with 1st gear bushing and 1st & 2nd synchronizer assembly.
- d. Remove mainshaft front snap ring.

DISASSEMBLY

Gear Components (Cont'd)

- e. Press out 3rd main gear together with 3rd & 4th synchronizer assembly and 3rd gear needle bearing.

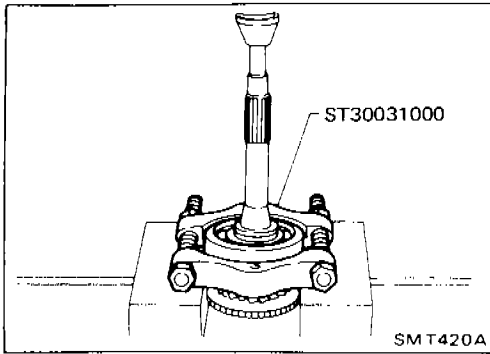
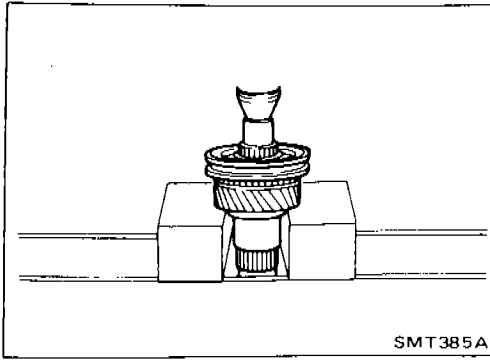

7. Remove main drive gear bearing.
 - a. Remove main drive gear snap ring and spacer.
 - b. Press out main drive gear bearing.

INSPECTION

Shift Control Components

- Check contact surface and sliding surface for wear, scratches, projections or other damage.

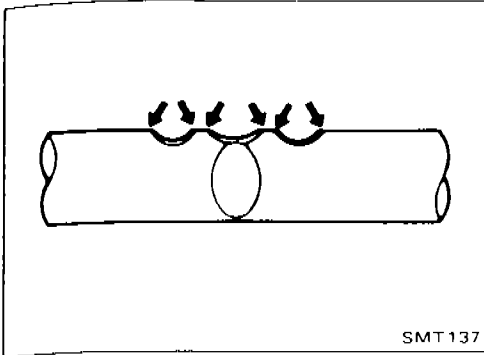

Gear Components

GEAR AND SHAFT

- Check shafts for cracks, wear or bending.
- Check gears for excessive wear, chips or cracks.

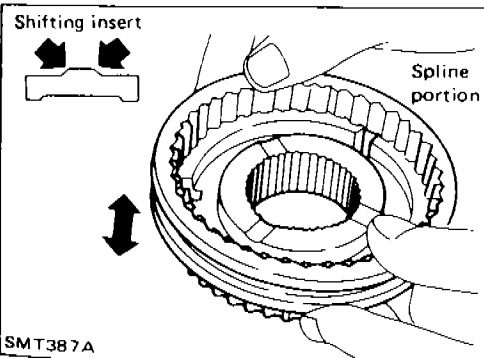
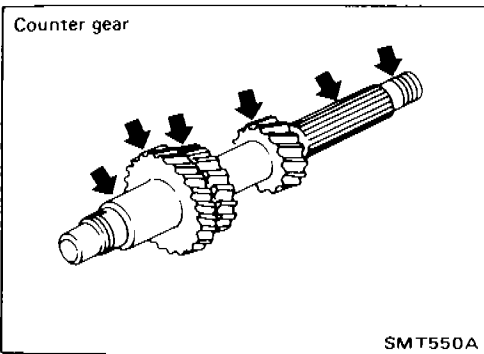
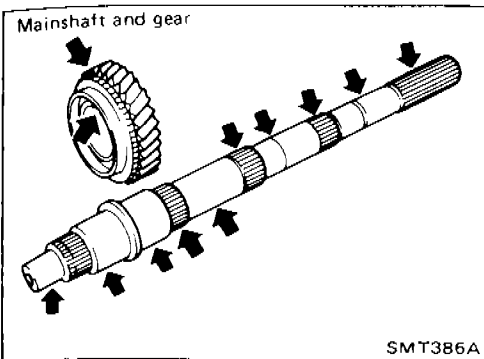

SYNCHRONIZERS

- Check spline portion of coupling sleeves, hubs and gears for wear or cracks.
- Check baulk rings for cracks or deformation.
- Check shifting inserts for wear or deformation.
- Check insert springs for deformation.

INSPECTION

Gear Components (Cont'd)

- Measure clearance between baulk ring and gear.
- Clearance between baulk ring and gear**
[1st, 3rd, main drive and O.D. baulk ring (For Europe), 1st, main drive and O.D. baulk ring (Except for Europe)]:

Unit: mm (in)

Dimension	Standard	Wear limit
1st	1.2 - 1.6 (0.047 - 0.063)	0.8 (0.031)
3rd and main drive	1.2 - 1.6 (0.047 - 0.063)	
O.D.	1.2 - 1.4 (0.047 - 0.055)	

If the clearance is smaller than the wear limit, replace baulk ring.

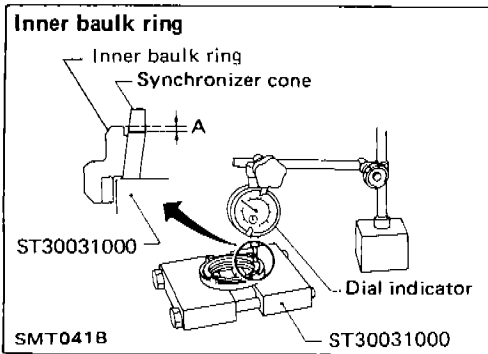
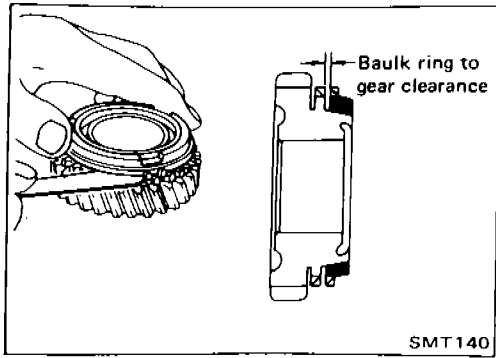

- Measure wear of baulk ring.
- [2nd baulk ring (For Europe), 2nd and 3rd baulk ring (Except for Europe)]**
- Place baulk rings in position on synchronizer cone.
 - While holding baulk rings against synchronizer cone as far as it will go, measure dimensions "A" and "B".

Unit: mm (in)

Dimension	Standard	Wear limit
A	0.6 - 1.1 (0.024 - 0.043)	0.2 (0.008)
B	0.7 - 0.9 (0.028 - 0.035)	

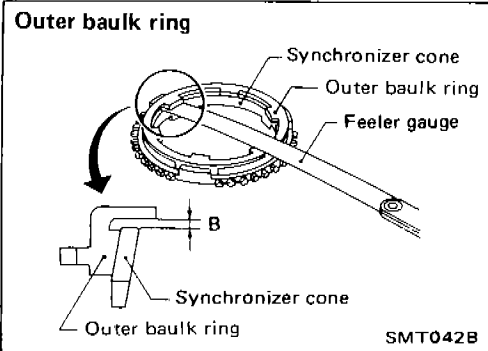

- If dimension "A" or "B" is smaller than the wear limit, replace baulk ring.

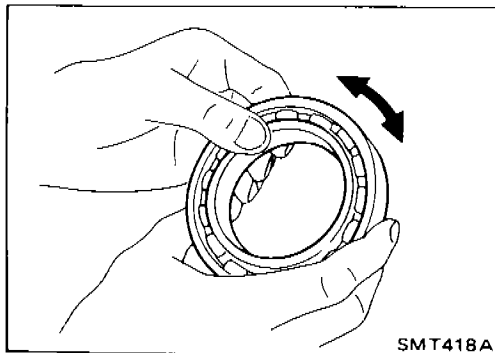

BEARINGS

- Make sure bearings roll freely and are free from noise, crack, pitting or wear.

ASSEMBLY

Gear Components

1. Install bearings into case components.

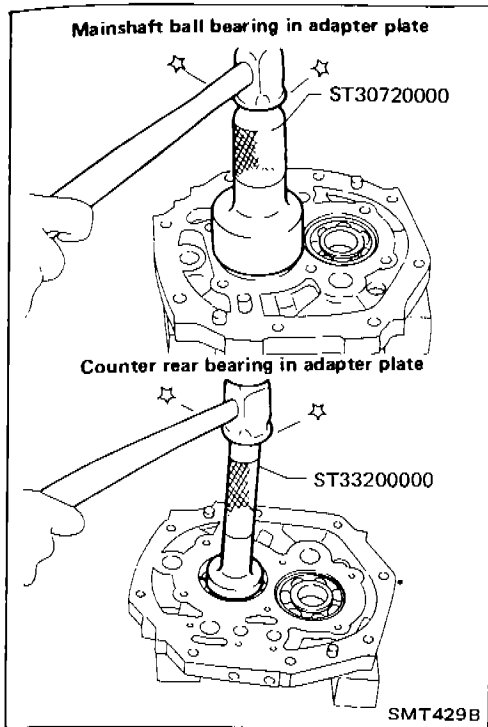

2. Assemble adapter plate parts.

- Install oil gutter on adapter plate and expand on rear side.

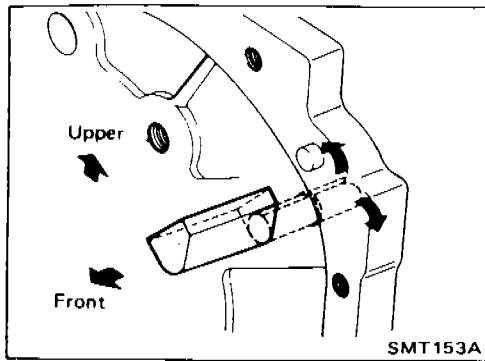

- Install bearing retainer.

- a. Insert reverse shaft, then install bearing retainer.

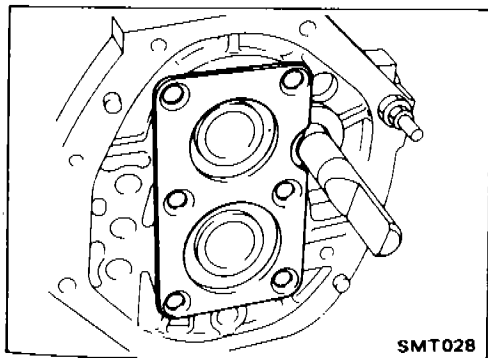

- b. Tighten each screw, then stake each at two points.

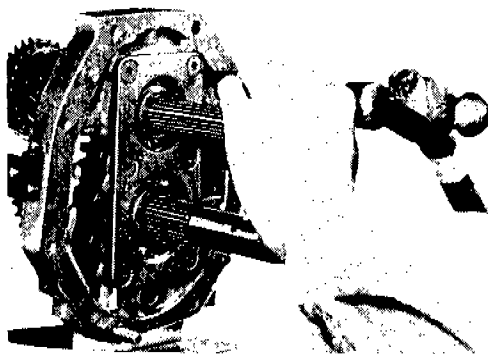

ASSEMBLY

Gear Components (Cont'd)

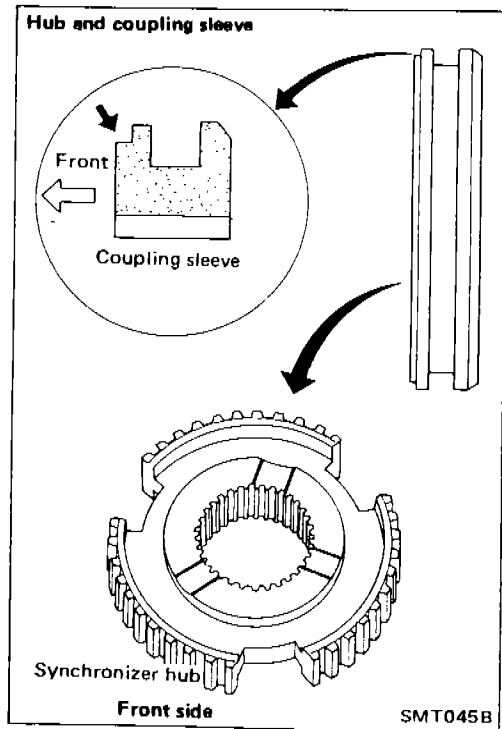
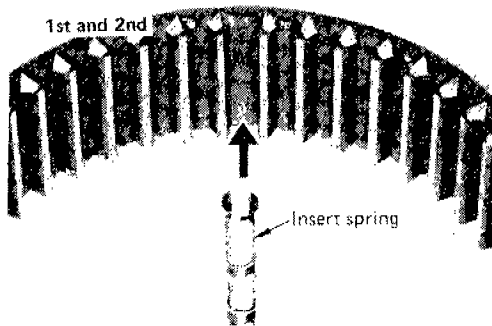
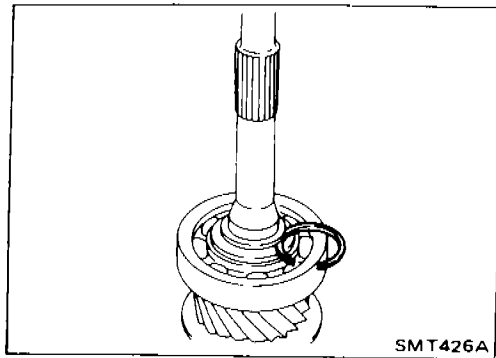
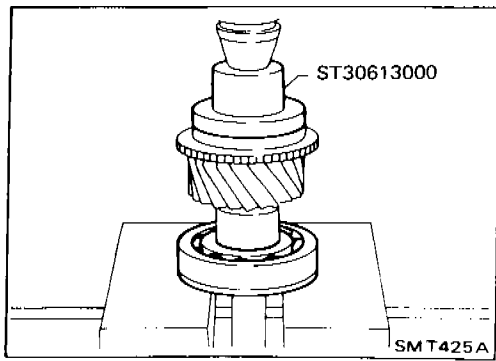

3. Install main drive gear bearing.
 - a. Press main drive gear bearing.
 - b. Install main drive gear spacer.

- c. Select proper main drive gear snap ring to minimize clearance of groove and install it.

Allowable clearance of groove:

0 - 0.13 mm (0 - 0.0051 in)

Main drive gear snap ring:

Refer to S.D.S.

4. Assemble synchronizers.

- 1st & 2nd synchronizer

- Check coupling sleeve and synchronizer hub orientation.

ASSEMBLY

Gear Components (Cont'd)

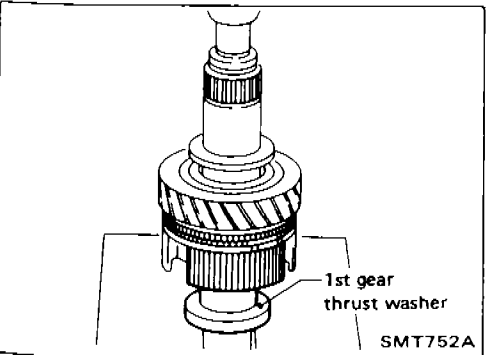
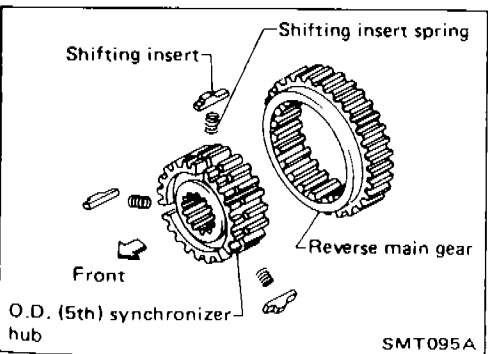
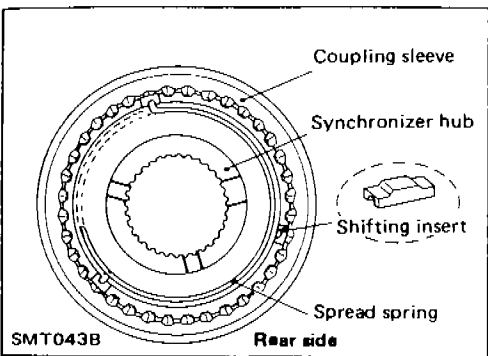
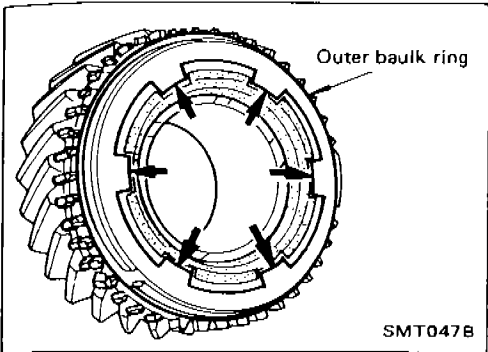
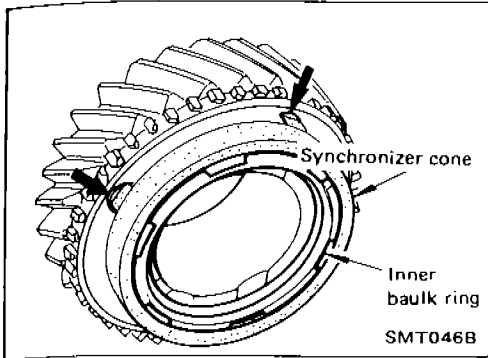

● 3rd & 4th synchronizer

● O.D. synchronizer

5. Install front side components on main shaft.
 - a. Assemble 2nd main gear, needle bearing and 1st & 2nd synchronizer assembly, then press 1st gear bushing on mainshaft.
 - b. Install 1st main gear.

ASSEMBLY

Gear Components (Cont'd)

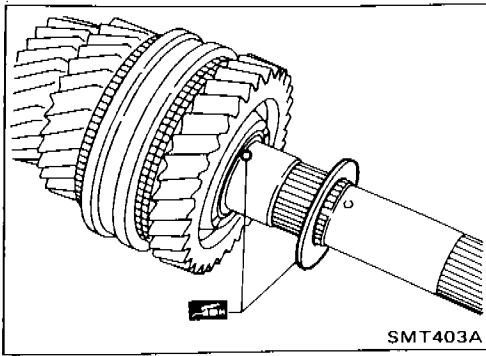

c. Install steel ball and 1st gear washer.

- Apply multi-purpose grease to steel ball and 1st gear washer before installing.

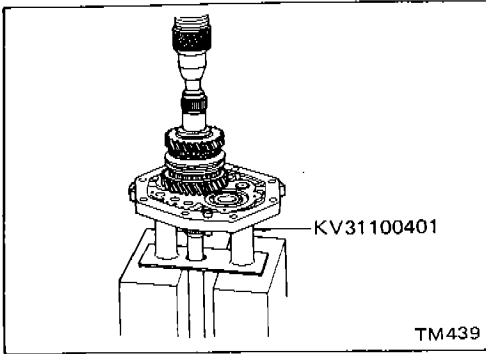

6. Install mainshaft and counter gear on adapter plate and main drive gear on mainshaft.

- a. Press mainshaft assembly to adapter plate with Tool.

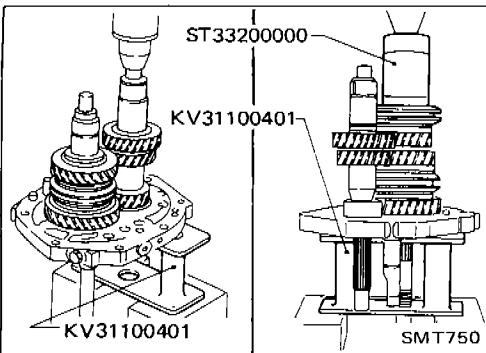

b. Press counter gear into adapter plate with Tool.

c. Install 3rd main gear and then press 3rd & 4th synchronizer assembly.

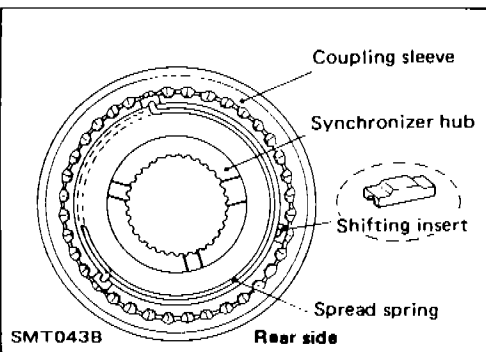

- Pay attention to direction of 3rd & 4th synchronizer.

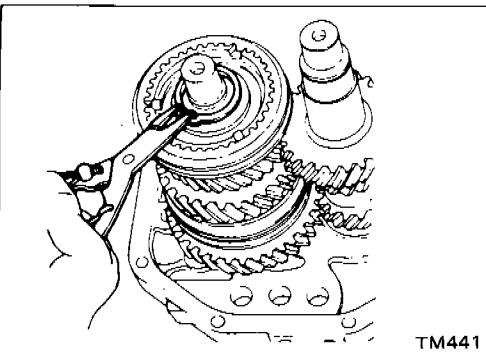

d. Install thrust washer on mainshaft and secure it with mainshaft front snap ring. Select proper snap ring to minimize clearance of groove in mainshaft.

Allowable clearance of groove:

0 - 0.18 mm (0 - 0.0071 in)

Mainshaft front snap ring:

Refer to S.D.S.

e. Apply gear oil to mainshaft pilot bearing and install it on mainshaft.

ASSEMBLY

Gear Components (Cont'd)

f. Press counter drive gear with main drive gear with Tool.

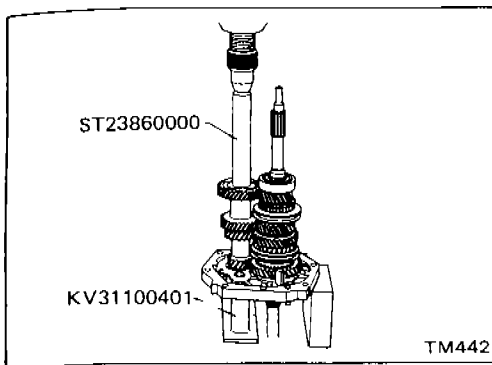

● Pay attention to direction of counter drive gear.

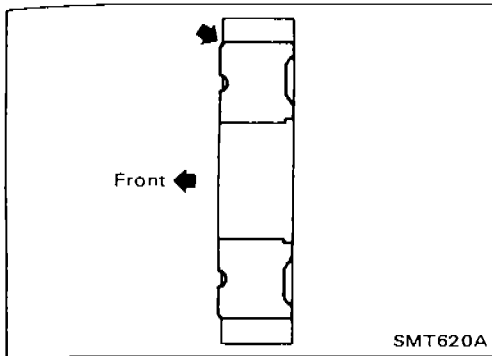

g. Install sub-gear components.

(1) Install sub-gear and sub-gear bracket on counter drive gear and then select proper snap ring to minimize clearance of groove in counter gear.

Allowable clearance of groove:

0 - 0.18 mm (0 - 0.0071 in)

Counter drive gear snap ring: Refer to S.D.S.

(2) Remove snap ring, sub-gear bracket and sub-gear from counter gear.

(3) Reinstall sub-gear, sub-gear spring and sub-gear bracket.

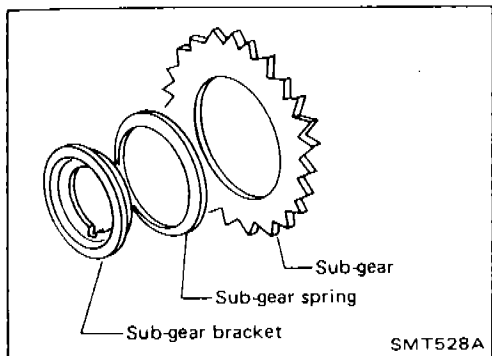

h. Install selected counter drive gear snap ring.

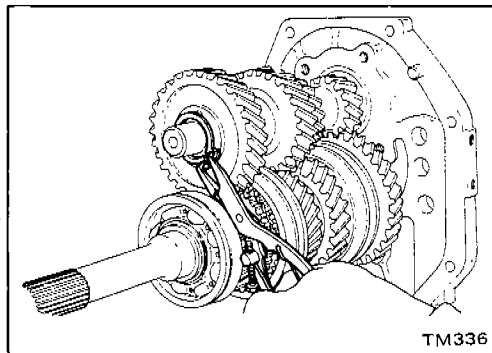

i. Press counter gear front bearing onto counter gear.

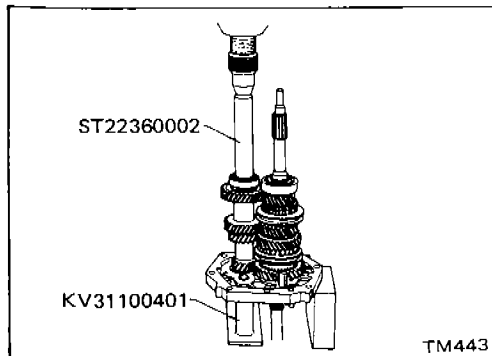

ASSEMBLY

Gear Components (Cont'd)

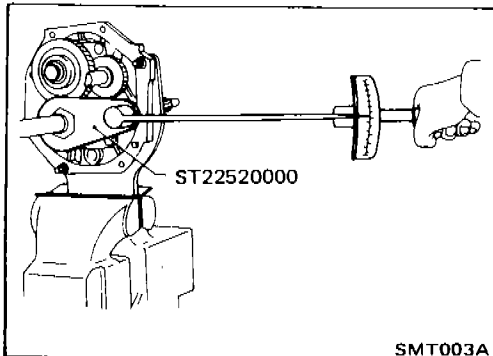
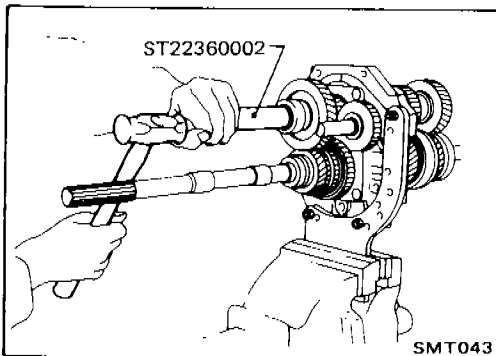
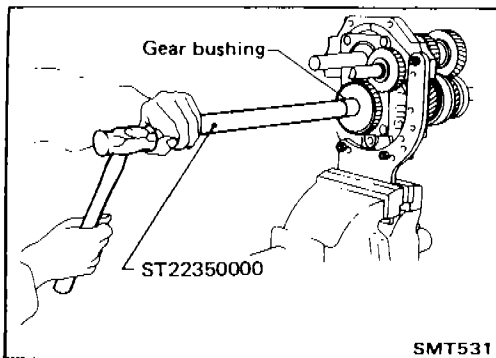
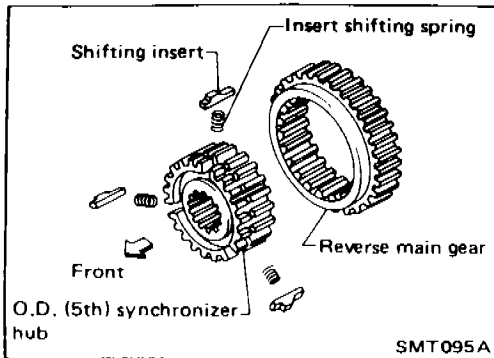
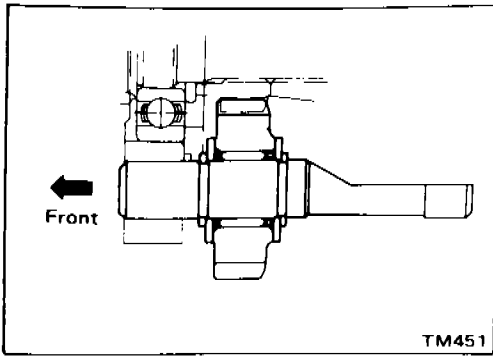

7. Install rear side components on mainshaft and counter gear.
- Install reverse idler gear to reverse idler shaft with spacers, snap rings and needle bearing.

- Install insert retainer and O.D. synchronizer to mainshaft.
 - Pay attention to direction of hub.

- Install O.D. gear bushing with Tool.
- Install O.D. main gear and needle bearing.
- Install spacer, reverse counter gear and O.D. counter gear.
 - O.D. main gear and O.D. counter gear should be handled as a matched set.
- Install washer, roller bearing, steel roller and thrust washer.
- Tighten mainshaft lock nut temporarily.
 - Always use new lock nut.

- Install countershaft rear end bearing with Tool.

8. Mesh 2nd and reverse gears, then tighten mainshaft lock nut with Tool.

ASSEMBLY

Gear Components (Cont'd)

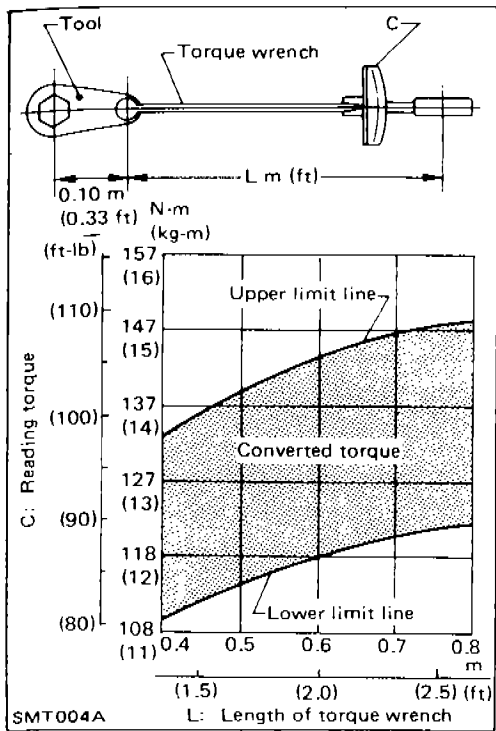

- Use the left chart when deciding the reading torque. (Length of torque wrench vs. setting or reading torque)
9. Tighten countershaft lock nut.
 - Always use new lock nut.

Mainshaft

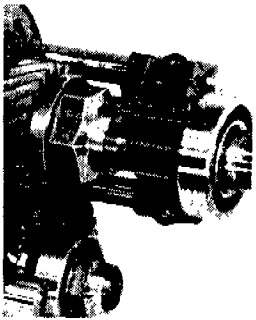

Countershaft

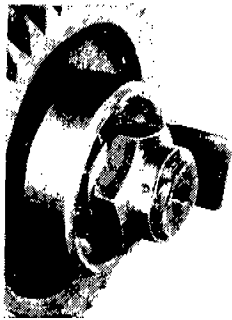

10. Stake mainshaft lock nut and countershaft lock nut with a punch.
11. Measure gear end play. For the description, refer to DIS-ASSEMBLY for Gear Components.

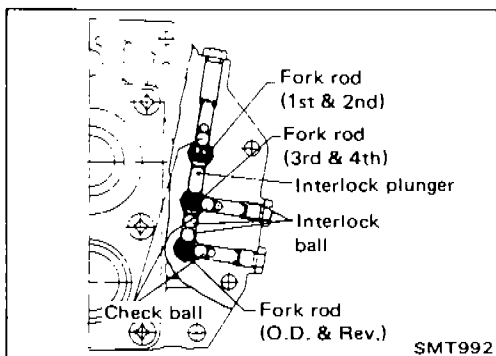

Shift Control Components

1. Install shift rods, interlock plunger, interlock balls and check balls.

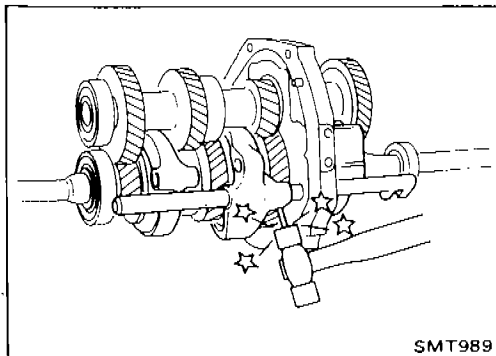

- a. 1st-2nd shift fork

ASSEMBLY

Shift Control Components (Cont'd)

b. 3rd-4th shift fork

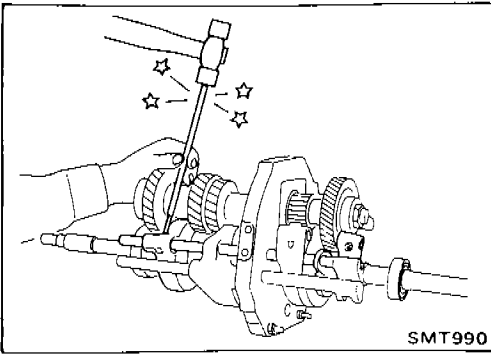

c. O.D.-reverse shift fork or reverse shift fork.

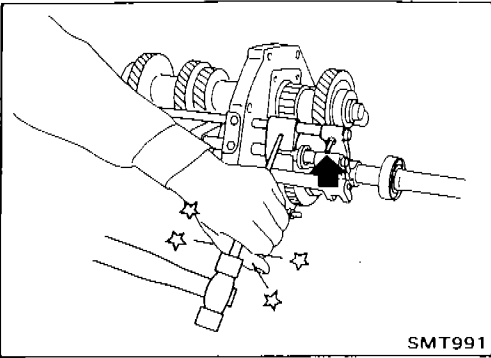

2. Install O.D. and reverse fork shaft by rotating O.D. and reverse bracket clockwise.

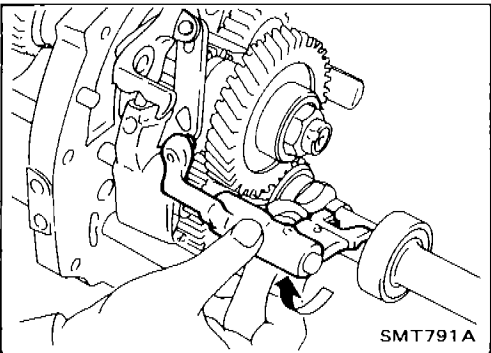

3. Install E-ring on O.D. and reverse fork rod.

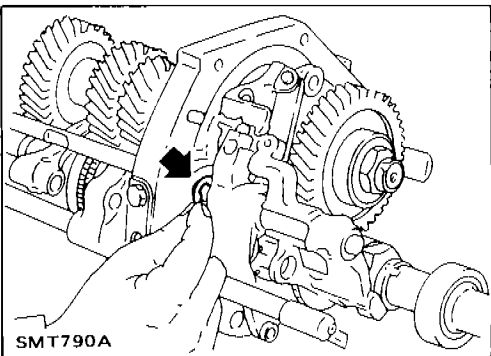

4. Install lever bracket securing bolt.

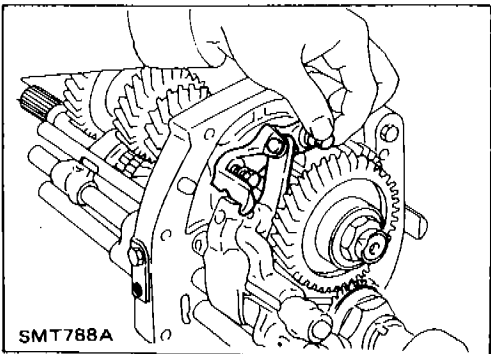

ASSEMBLY

Case Components

1. Install front cover oil seal.
 - Apply multi-purpose grease to seal lip of oil seal before installing.

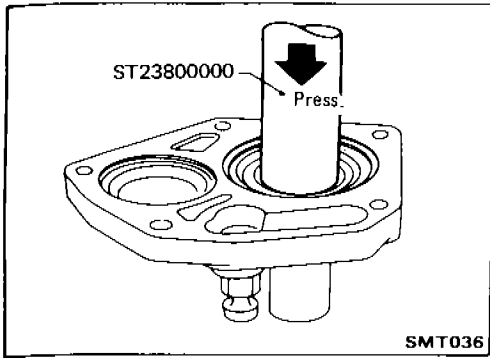

2. Apply sealant to mating surface of transmission case.

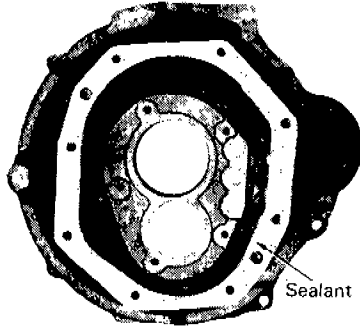

3. Install gear assembly onto transmission case.

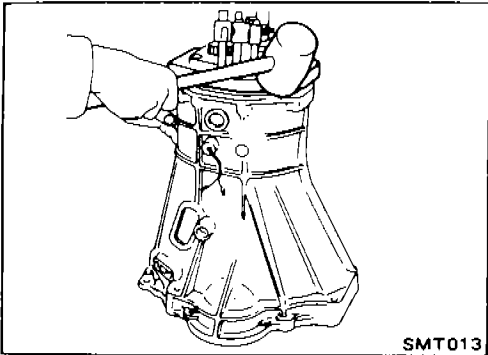

4. Install snap ring of main drive bearing.

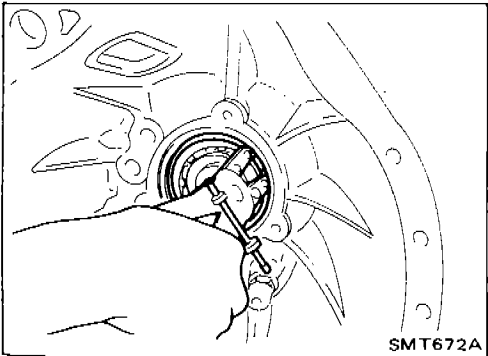

5. Apply sealant to mating surface of adapter plate.
6. Install rear extension.

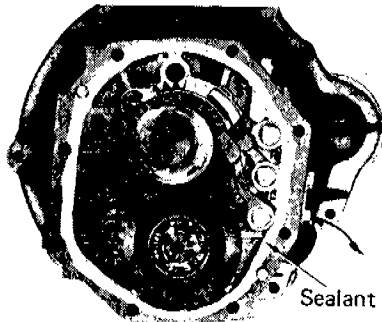

ASSEMBLY

Case Components (Cont'd)

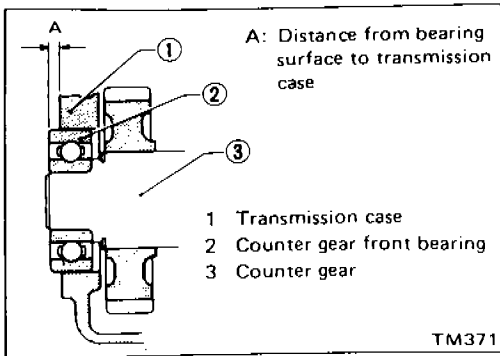

7. Select counter front bearing shim.

Counter front bearing shim: Refer to S.D.S.

8. Install gasket and front cover.

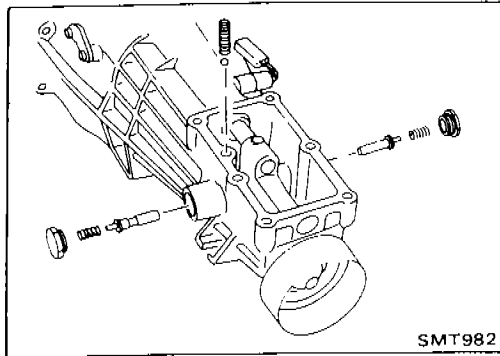

9. Install return spring plugs, check ball, return springs and select check plunger.

10. Install control housing and gasket.

SERVICE DATA AND SPECIFICATIONS (S.D.S)

General Specifications

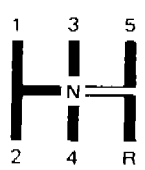
Destination	Except Europe	Europe	
Transmission model	FS5W71C		
Number of speeds	5		
Shift pattern			
Synchromesh type	Warner		
Gear ratio			
1st	3.321	3.592	
2nd	1.902	2.057	
3rd	1.308	1.361	
4th	1.000	1.000	
O.D.	0.838	0.821	
Reverse	3.382	3.657	
Number of teeth			
Mainshaft			
Drive	22	21	
1st	33	33	
2nd	27	27	
3rd	26	25	
O.D.	21	22	
Reverse	36	36	
Countershaft			
Drive	31	32	
1st	14	14	
2nd	20	20	
3rd	28	28	
O.D.	37	39	
Reverse	15	15	
Reverse idler gear	21		
Oil capacity	ℓ (Imp pt)	2.4 (4-1/4)	
Remarks	Sub-gear	○	
	Mainshaft braking mechanism	○	
	Double baulk ring type synchronizer	2nd and 3rd synchronizer	2nd synchronizer

SERVICE DATA AND SPECIFICATIONS (S.D.S)

Inspection and Adjustment

GEAR END PLAY

Gear	End play mm (in)
1st gear	0.31 - 0.41 (0.0122 - 0.0161)
2nd gear	0.11 - 0.21 (0.0043 - 0.0083)
3rd gear	0.11 - 0.21 (0.0043 - 0.0083)
O.D. gear	0.24 - 0.41 (0.0094 - 0.0161)

CLEARANCE BETWEEN BAULK RING AND GEAR For Europe

1st, 3rd, main drive and O.D. baulk ring

Unit: mm (in)

	Standard	Wear limit
1st	1.2 - 1.6 (0.047 - 0.063)	0.8 (0.031)
3rd and main drive	1.2 - 1.6 (0.047 - 0.063)	
O.D.	1.2 - 1.4 (0.047 - 0.055)	

2nd baulk ring

Unit: mm (in)

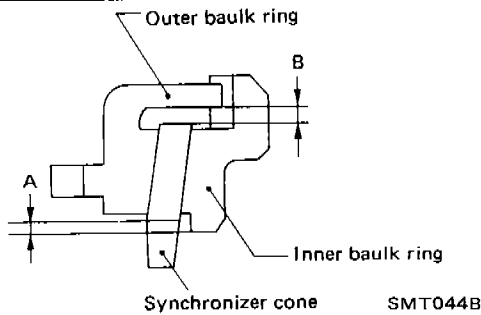

Dimension	Standard	Wear limit
A	0.6 - 1.1 (0.024 - 0.043)	0.2 (0.008)
B	0.7 - 0.9 (0.028 - 0.035)	

Except for Europe

1st, main drive and O.D. baulk ring

Unit: mm (in)

	Standard	Wear limit
1st	1.2 - 1.6 (0.047 - 0.063)	0.8 (0.031)
O.D.	1.2 - 1.4 (0.047 - 0.055)	

2nd and 3rd baulk ring

Unit: mm (in)

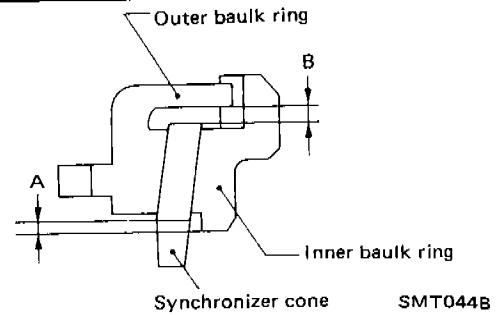

Dimension	Standard	Wear limit
A	0.6 - 1.1 (0.024 - 0.043)	0.2 (0.008)
B	0.7 - 0.9 (0.028 - 0.035)	

AVAILABLE SNAP RINGS

Main drive gear bearing

Allowable clearance 0 - 0.13 mm (0 - 0.0051 in)

Thickness mm (in)	Part number
1.73 (0.0681)	32204-78005
1.80 (0.0709)	32204-78000
1.87 (0.0736)	32204-78001
1.94 (0.0764)	32204-78002
2.01 (0.0791)	32204-78003
2.08 (0.0819)	32204-78004

Mainshaft front

Allowable clearance 0 - 0.18 mm (0 - 0.0071 in)

Thickness mm (in)	Part number
2.4 (0.094)	32263-V5200
2.5 (0.098)	32263-V5201
2.6 (0.102)	32263-V5202

Mainshaft rear end bearing

Allowable clearance 0 - 0.14 mm (0 - 0.0055 in)

Thickness mm (in)	Part number
1.1 (0.043)	32228-20100
1.2 (0.047)	32228-20101
1.3 (0.051)	32228-20102
1.4 (0.055)	32228-20103

SERVICE DATA AND SPECIFICATIONS (S.D.S)

Inspection and Adjustment (Cont'd)

Counter drive gear

Allowable clearance 0 - 0.18 mm (0 - 0.0071 in)

Thickness mm (in)	Part number
1.4 (0.055)	32215-E9000
1.5 (0.059)	32215-E9001
1.6 (0.063)	32215-E9002

AVAILABLE SHIMS

Counter front bearing

Unit: mm (in)

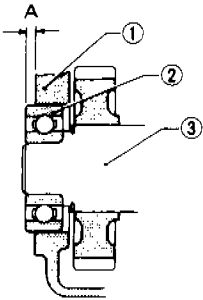

A: Distance from bearing surface to transmission case

- 1 Transmission case
- 2 Counter gear front bearing
- 3 Counter gear

TM371

"A"	Thickness of shim	Part number
4.52 - 4.71 (0.1780 - 0.1854)	Not necessary	
4.42 - 4.51 (0.1740 - 0.1776)	0.1 (0.004)	32218-V5000
4.32 - 4.41 (0.1701 - 0.1736)	0.2 (0.008)	32218-V5001
4.22 - 4.31 (0.1661 - 0.1697)	0.3 (0.012)	32218-V5002
4.12 - 4.21 (0.1622 - 0.1657)	0.4 (0.016)	32218-V5003
4.02 - 4.11 (0.1583 - 0.1618)	0.5 (0.020)	32218-V5004
3.92 - 4.01 (0.1543 - 0.1579)	0.6 (0.024)	32218-V5005